



ATLANTIS

SHAPE GREATNESS

OWNER'S MANUAL

2022

TABLE OF CONTENTS

- 09 ASSEMBLY INSTRUCTIONS
- 07 SAFETY INSTRUCTIONS
- 08 PREVENTIVE MAINTENANCE AND INSPECTION
- 13 REPLACING PARTS
- 15 TROUBLE SHOOTING
- 16 WARRANTY POLICY
- 19 CONTACT INFORMATION

This manual will provide you and your staff with valuable information regarding the operation and maintenance of your Atlantis equipment so that your members enjoy years of safe and exhilarating strength training pleasure.

USING THIS MANUAL

All Atlantis units can be identified by a code that features 1 or 2 letters, and 3 numbers. For example, the code P140 identifies the selectorized Seated Chest Press. All weight stack units (selectorized units) and plate-loaded units feature instructional **placards** that have their product codes printed on them as well. All other units may be identified by the product code found in your catalog, by the **serial number** (silver sticker near the bottom of the frame with 5 numbers) or by describing the unit's function and features to a representative.



P140 (01-0142)

Placards



Serial number

FEEL THE STRENGTH

Please note: The information in this manual pertains to models produced January 1st, 2020 and later. Do not apply any recommendation or instruction found in this manual to units produced before the aforementioned date without consulting our Atlantis service department first.

ASSEMBLY INSTRUCTIONS

The required tools for assembly are:



Impact driver or ratchet
socket wrench fitted with
9/16" (14 mm) socket

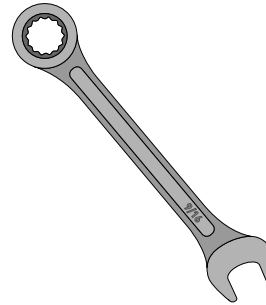
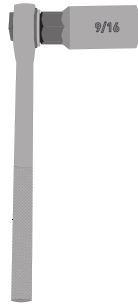

9/16" (14 mm)
wrench or
crescent wrench

The tools listed above are required to install weight stacks, remove pads and disassemble any Atlantis bolt combination. Bolts need to be removed with impact driver or ratchet fitted with 9/16" (14 mm) socket and 9/16" (14 mm) wrench or crescent wrench. Be sure to re-install all bolts and washer's combinations in the same order they were removed. Atlantis strongly recommends at least two people perform the following procedures for safety and comfort.

⚠ WARNING: Please note that shipping units (even over very short distances) can loosen the tightest of bolts. It is therefore extremely important that all bolts be carefully tightened before any equipment is used and on a regular basis thereafter.

RACKS, BENCHES AND PLATE-LOADED UNITS

These units are typically shipped fully assembled and ready to use. In some instances, units will be “compressed” to save space for shipping and are assembled with shortened beams. It is important to note that although the shortened beams are discarded after shipping, the hardware (bolts) must be reused. If a pad has been removed for installation purposes, be careful not to over tighten the T-nut bolts when reinstalling the pad on the unit. In order to do so, tighten the bolts by hand before using a ratchet or impact driver.

WEIGHT STACK UNITS

Weight stack units are typically shipped fully assembled apart from their weight stacks which are packed in boxes. It is important to follow the diagram labeled on each machine to make sure that the proper plates are installed.

Please note that the following units do not feature the 5 lb (2.3 kg) add-on weights described within the installation instructions:

- C113 Total Hip
- M118 Standing Calf
- M318 Incline Calf Raise
- NM205 Dynamic Functional Training System



5 lb (2.3 kg) add-on weights

1 WEIGHT STACK UNITS: INSTALLING THE WEIGHT STACK

- 1) First remove the top panel (A) from the top of the machine. Next, manually slide out the unit's protective shroud (B) from its tracks on the sides of the frame and put it aside.
- 2) Lower the add-on weights so that they are resting on the top plate. This will expose the two silver cylindrical bolts and black plastic bracket (C) holding the chromed guide rods (D) in place. Loosen and remove both cylindrical bolts and the black plastic bracket.

On most stations, you will find special "split" washers (also called

lock washers) and "flat" washers between the cylindrical bolt and the bracket that are very important. They keep the bolts from vibrating loose over time. Securely install the "flat" washer under the plastic bracket (C) and the "split" washer between the cylindrical bolt and the "flat" washer. On other stations, you will find regular nut and bolt assemblies that do not require these washers. Carefully let the guide rods lean to whichever side of the unit is easiest to work on. The rods will lean about 60 degrees and sit safely in place on an angle.

- 3) Remove the two add-on weights.

- 4) Grasp the top plate (hanging on either a belt or a cable) and slide it off the top of the guide rods. Let the top plate (E) hang on the belt or cable and place it to one side.
- 5) Slide all the weight plates (F) onto the guide rods one at a time as per the diagram. Slide the hanging top plate back onto the guide rods to complete the weight stack without twisting the belt or cable.

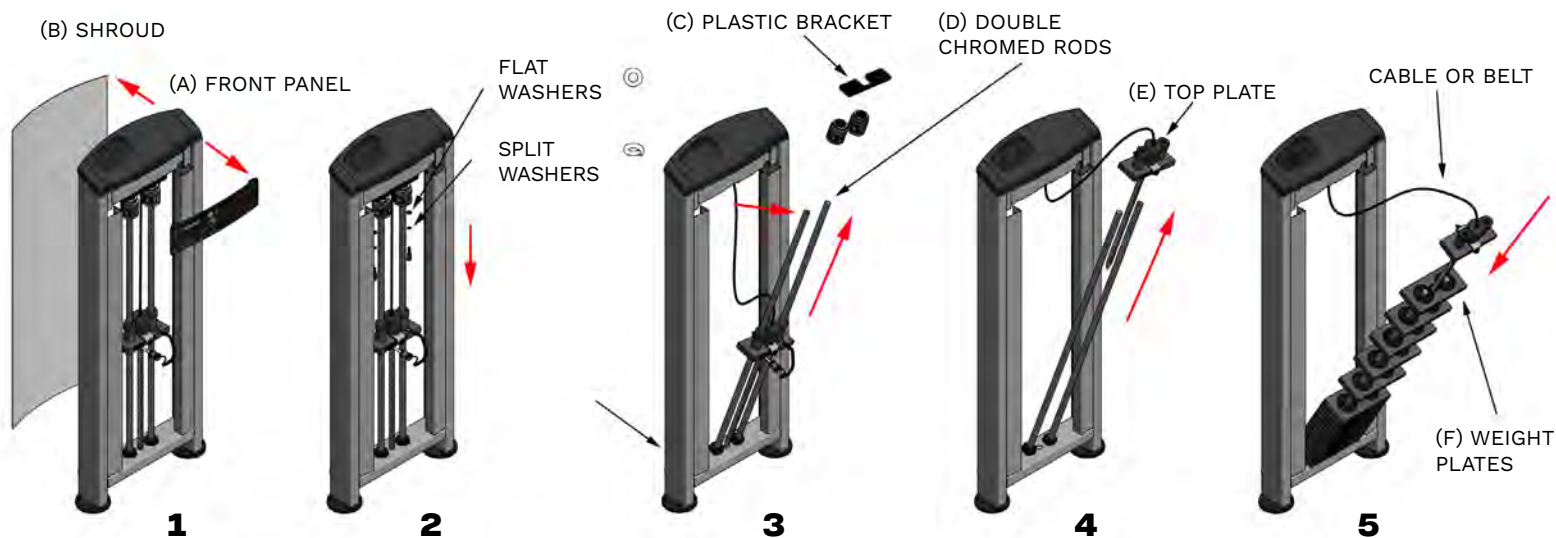

I WEIGHT STACK UNITS: INSTALLING THE WEIGHT STACK

- 6) Slide back the two add-on weights (G).
- 7) Push the rods back into place. Place the black plastic bracket into position and secure it to the frame with the cylindrical bolts. Replace the “split” and “flat” washers. (See p. 5, #2)
- 8) Slide each add-on weight up the guide rod and twist it into the stored position on the cylindrical bolt.
- 9) Put the weight sticker on each plate as per diagram. NOTE: Fronts of plates should be wiped with rubbing alcohol before the stickers are applied to remove surface oils and to ensure proper adhesion.
- 10) Put the shroud and front panel back.

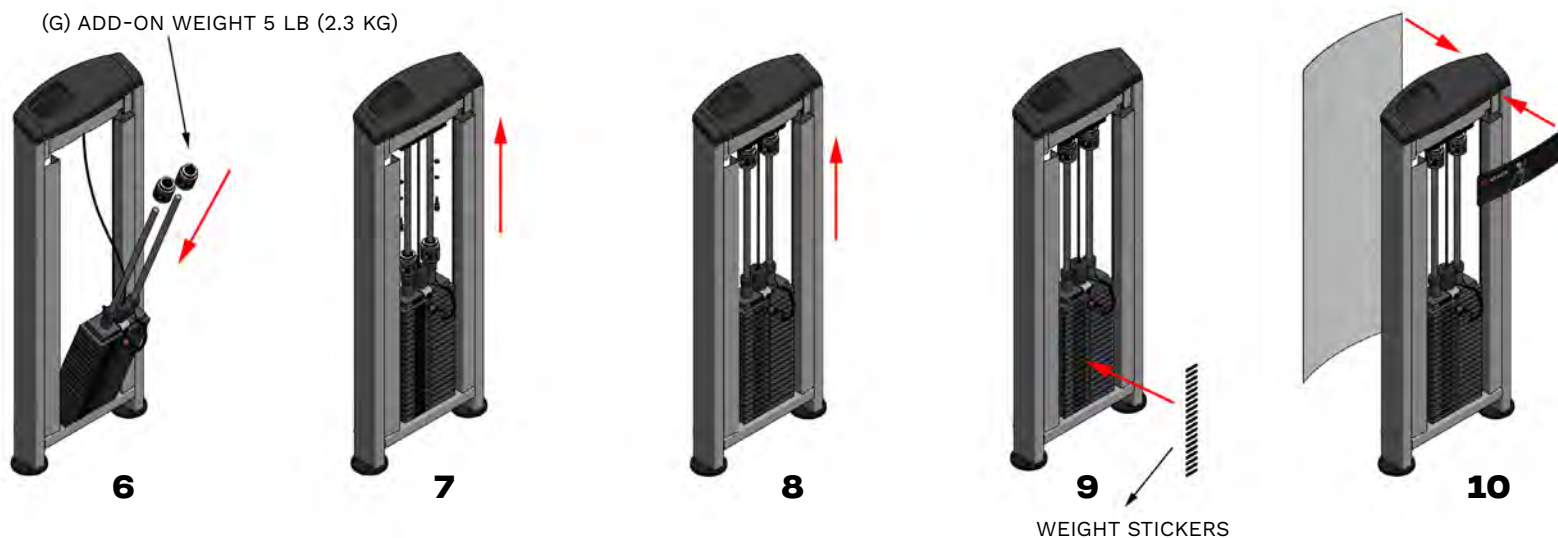

SAFETY INSTRUCTIONS

Your Atlantis equipment has been carefully designed to be used safely under normal operating conditions. However, the practice of educating individuals who encounter your equipment and properly inspecting and maintaining units on a regular basis (see *(3) Preventive Maintenance* in this manual) will greatly enhance the safety level of your facility. Anyone who comes into contact with the equipment must be familiar with its operation and the potential hazards associated with improper use or maintenance.

- **Read all warnings** and obtain instructions before using Atlantis equipment. Use each unit for its intended exercise(s) only. **Do not modify a unit in any way.**
- Ensure that all users obtain a medical exam and receive proper instructions before using Atlantis equipment.
- Users and bystanders must keep all body parts and clothing away from moving parts during use.
- **Follow the suggested inspection schedule** found in this manual. Do not allow anyone to use a unit if it appears to be damaged. Do not attempt to fix a broken or jammed machine if you are not qualified to do so.
- **Use only the weight selector pin provided by the manufacturer.** Do not improvise. If in doubt, consult an Atlantis representative prior to any intervention.
- Do not use dumbbells, weight plates or any other means to add resistance to weight stack (selectorized) units.
- Do not exceed personal strength levels or overload equipment.
- Keep children away from equipment and supervise teenagers.
- Do not remove any labels from Atlantis equipment. **Replace damaged labels immediately.**

Atlantis recommends that all equipment be secured to the floor, to a solid, level surface to avoid tipping over or rocking. This must be performed by a licensed contractor.

PREVENTIVE MAINTENANCE AND INSPECTION

Every step in the design and production phase of manufacturing is taken to ensure that your Atlantis equipment will operate safely and efficiently under normal conditions and in commercial settings for prolonged periods of time. However, as with any machinery with moving parts, your equipment is subject to wear and must be maintained and inspected on a regular basis. Failure to do so will cause unnecessary damage or premature wear on a unit's components, and in turn pose serious safety hazards to users.

Every weight stack and linear bearing needs to be treated specifically by following the recommendations provided in this manual. If in doubt, consult an Atlantis representative prior to any intervention.

Atlantis will not be held responsible for any personal injury or damages resulting from improper maintenance, misuse or negligence.

MAINTENANCE AND INSPECTION SCHEDULE: DAILY MAINTENANCE

- Clean upholstery with any upholstery safe sanitizing spray using a soft damp cloth (clean, sweat-free upholstery lasts up to 40% longer). For especially persistent stains, apply rubbing alcohol liberally with a soft cloth and wipe dry with another cloth after rinsing area with clean water.
- Recommended upholstery cleaning products:

Primary: Formula 409 All-Purpose Cleaner

Secondary:

- Lysol Clean and Fresh Multi-Surface Cleaner (Reckitt Benckiser)
- Lestoil Heavy Duty Cleaner (Clorox)
- Mr. Clean / Flash Clean and Shine (Procter and Gamble)
- Eco Touch All Purpose Premium Care

⚠ Do not use abrasive powder, steel wool, or industrial strength or solvent cleaners. The use of upholstery “conditioners” or “protectants” is not recommended and should be avoided on all vinyl coated fabrics. Also note that repeated use of any disinfectants and cleaning agents will degrade coated fabrics upholstery to some extent. For high traffic/wear applications that require repeated cleaning and disinfecting, it is recommended to use coated fabric products with PreFixx® Protective Finish.

I MAINTENANCE AND INSPECTION SCHEDULE: WEEKLY MAINTENANCE

- Clean weight stack guide rods with dry towel and lubricate with TFL- 50 wet lube. Do not use silicone or any other type of lubricant. Wipe guide rods clean and apply lubricant from the top down, allowing slight excess to run down guide rods and into the weight stack. If using a spray can or bottle, be sure to shield the rest of the unit from over spray as product can stain. Occasionally, have an assistant lift the weight stack at different weight values (exercise extreme caution when performing this maneuver), and apply lubricant to the portions of the guide rods that are usually hidden by the weight stack if they seem dry. Weight stack guide rods should be clean and have a light layer of lubricant on them for optimal performance. Failing to wipe guide rods clean first will lead to unwanted resistance and premature wear on bushings.
- Clean linear bearing guide rods on Smith machines (E155) with a dry towel and lubricate with multipurpose grease. Do not use silicone or any other type of lubricant. Atlantis recommends the spray format of Super Lube®, an excellent multipurpose Teflon-based lubricant.
- Lightly grease stainless steel seat shafts and backrests, accessory bars, and pivoting handles with multipurpose grease or Super Lube®. Never lubricate the piston shaft of a hydraulic or gas spring shock.
- Inspect all labels. Replace any damaged or missing labels.
- Tighten all nuts and bolts.

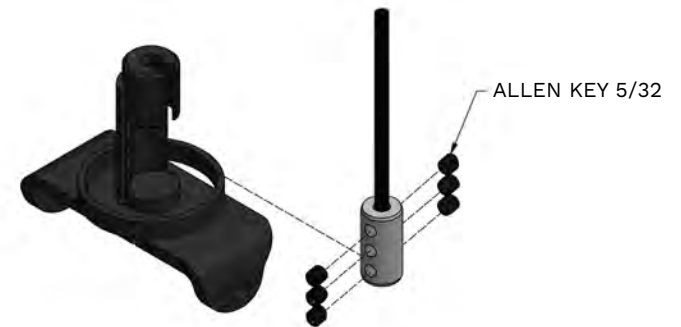
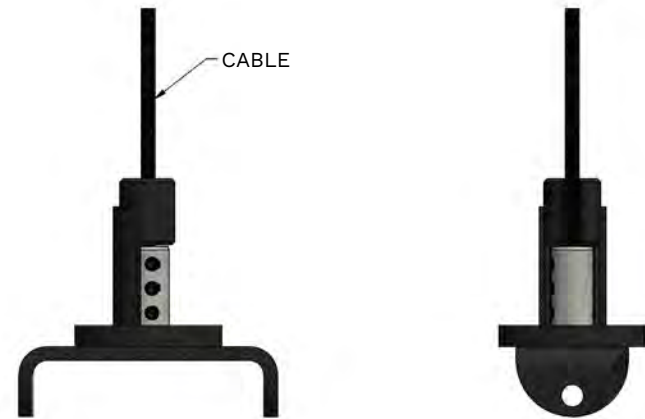

ASSEMBLY WITH TOP PLATE BRACKET

MAINTENANCE AND INSPECTION SCHEDULE: MONTHLY MAINTENANCE

- Check cables for correct tension on crossovers, adjustable pulleys and functional training systems (NM200/NM205). If the cable is loose, use the cable adjustment screw attached to the housing of the pulley assembly (see figures below). The cable will tighten as the screw goes down.
- Clean frames and inside of weight stack shrouds with a solution of Simple Green® All-Purpose Cleaner (an environmentally-friendly, non-toxic, and biodegradable cleaner). Dirt and dust are your machine's worst enemy! Keeping units clean is an important part of their performance and durability.

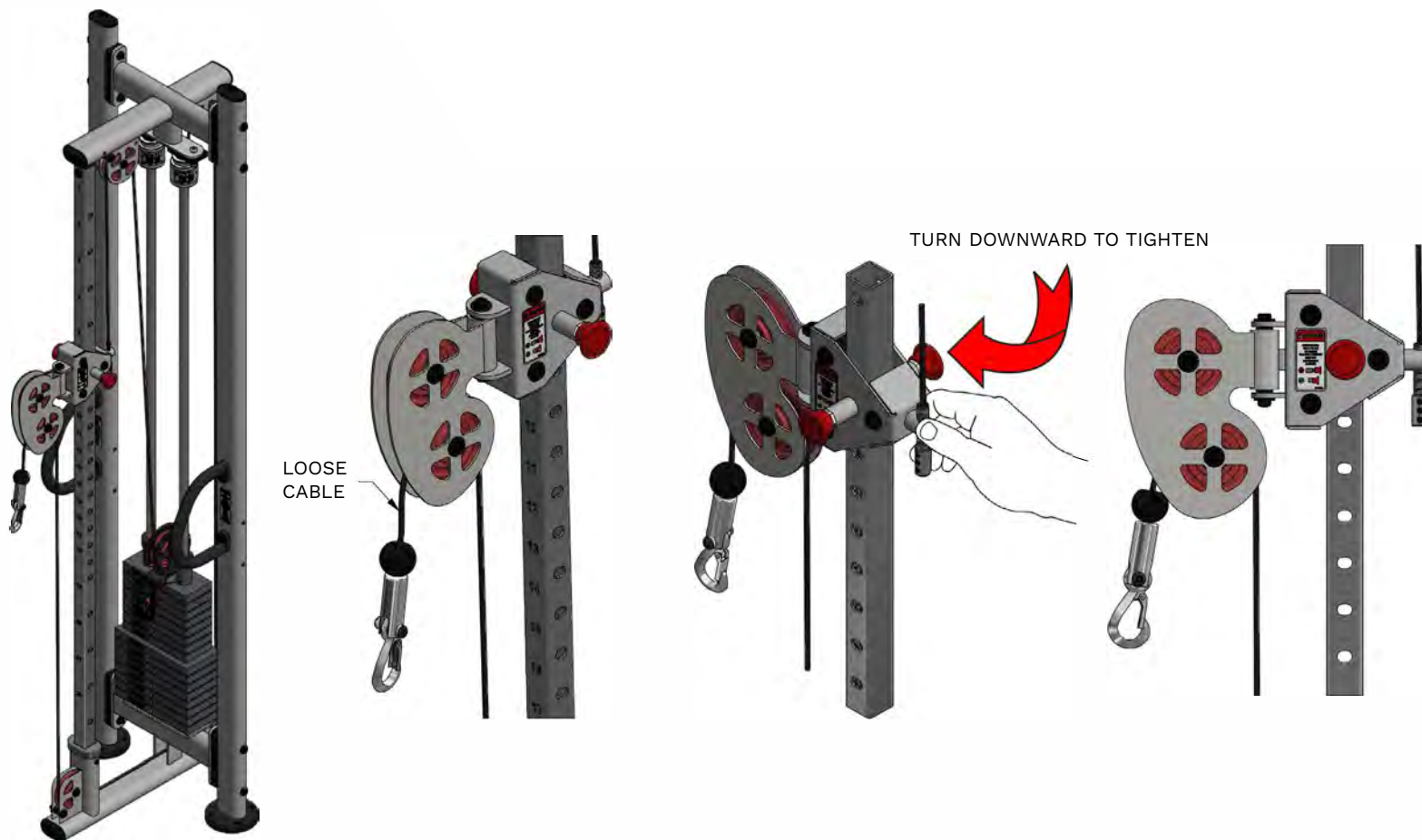

| MAINTENANCE AND INSPECTION SCHEDULE: YEARLY MAINTENANCE

- Clean frames as indicated above and polish with automotive grade wax to protect finish from surface rust and corrosion. This recommendation is especially pertinent for facilities located in high-humidity regions.

| ORDERING RECOMMENDED LUBRICANTS

To order TFL-50 in Canada: contact Atlantis by email at service@atlantisstrength.com or from 8:30 am - 4:30 pm Eastern Standard Time (UTC-5) at 1-877-454-2285, ext. 239.

To order TFL-50 in the United States or internationally: contact TFL International from 8 am - 4 pm Eastern Standard Time (UTC-5) at 1-514-992-9131 or send an email to earl@tfl50.com

To order Super Lube in Canada: contact Atlantis by email at service@atlantisstrength.com or from 8:30 am - 4:30 pm Eastern Standard Time (UTC-5) at 1-877-454-2285, ext. 239.

CABLES

Cables come in two different sizes: 1/8" (3 mm) and 3/16" (4.8 mm). The 1/8" (3 mm) cable is more flexible and is used for units with a total weight stack of up to 200 lb (91 kg). The 3/16" (4.8 mm) cable is less malleable and recommended for units with a weight stack over 200 lb (91 kg).

If unsure of the cable size to use, please contact a customer service representative.

❶ **NOTE: The A201 and A301 are the only machines that use a Kevlar belt instead of a cable.**

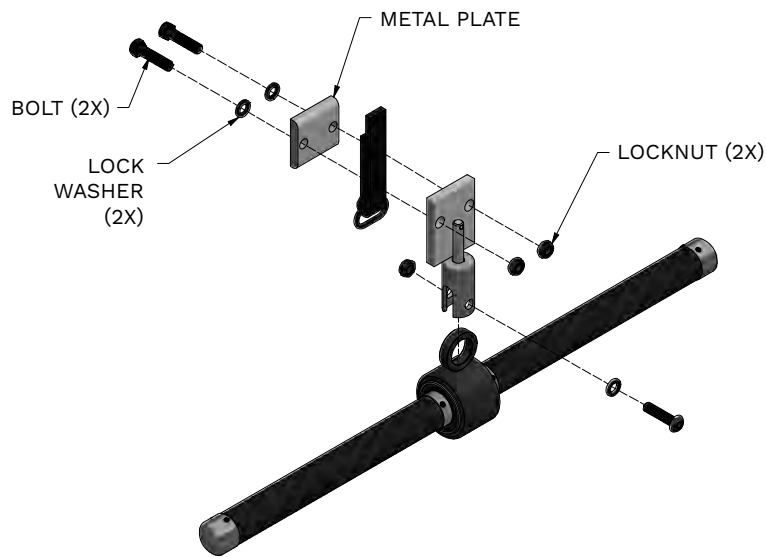
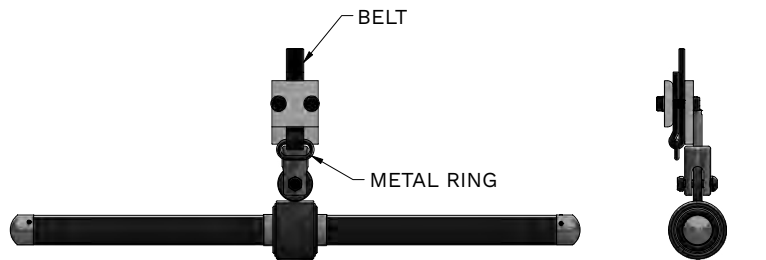

BELT: A201

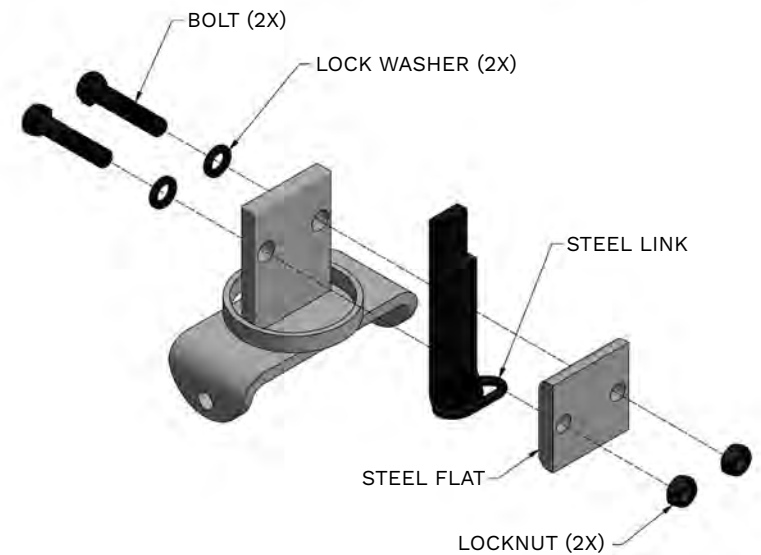
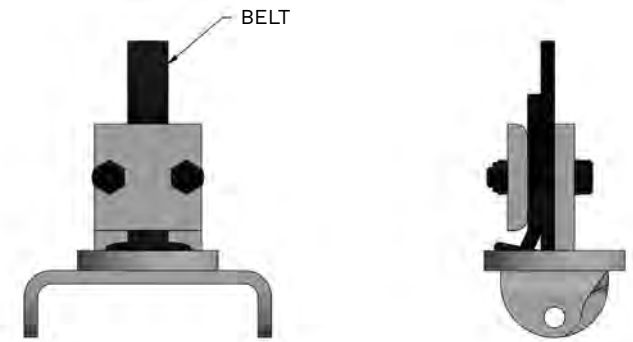

BELT: A301

PULL PINS

If the spring inside the pull pin mechanism is not working properly or other parts are missing, the entire pin needs to be changed.

It is important to note that the thread size of the pull-pin's insert changed sometime in early 2004. As a result, replacement pull-pins are shipped with two thread-sized nuts to accommodate all equipment models. Once the correct size has been identified, it is extremely important that the pull pin head (red) be glued using a thread locker (LOCTITE Red Threadlocker).

OTHER PARTS

If you need to replace a part that has not been listed in this manual, contact the service department with the product code and serial number with a description of the part you need. You may be required to provide additional information in order to help establish exactly which version of a part is required such as pictures of the unit and of the part(s) in question.

PADS

Please contact our service department with the following information relating to the unit such as model number, serial number, pictures and location of pad(s) on the unit so that we may be able to assist you.

ⓘ NOTE: Atlantis will evaluate if the foam is still in good condition, and thus only the upholstery needs to be changed.

I HYDRAULIC SEAT ADJUSTMENT

The hydraulic cylinders used to adjust seats on many of our selectorized units are tested for 350,000 cycles and are extremely durable. Their resistance level is pre-set at the factory and cannot be adjusted in the field. The seat adjustment may respond slowly during the initial use. See (3) Preventive Maintenance in this manual for lubrication instructions regarding the stainless steel seat shafts (NOT the cylinder shaft). If poor performance persists over a prolonged period, inspect the shock for signs of leakage and contact a customer service representative.

I GAS SPRING SHOCK (VARIOUS APPLICATIONS)

Gas spring shocks are used on pre-stretch pedals and in various other applications (either hidden or exposed) to assist users when adjusting heavy parts.

If the pre-stretch pedal does not return to starting position automatically, the shock has lost its resistance. If faced with this situation, begin by lubricating the shaft (and NOT the shock). If the shock is leaking or does not retract automatically, it may need to be replaced. Communicate the unit's model number and serial number as well as the exact position of the shock in question to your customer service representative. Gas spring shocks are sensitive to the position in which they are installed. A replacement shock must be re-installed exactly as the original shock was installed (not upside down), or the new shock will quickly dry out and fail.

I FRICTION/UNUSUAL RESISTANCE

Light friction on new units is normal. However, it is important to keep units well lubricated during the first month of operation for optimal performance and to decrease friction caused by new components.

Inspect all pivoting connecting parts and replace them immediately if worn.

WARRANTY POLICY

All products manufactured by Atlantis are warranted to the original purchaser to be free from defects in workmanship and / or materials under normal use or service as follows:

ATLANTIS EQUIPMENT

- 10 years:** Structural frame and moving parts, welds and weight stack plates
- NOTE: Labor costs related to these warranty items will be covered by Atlantis for 1 year following the delivery date provided that the equipment is located within Atlantis' or its distributors' service zones. Please refer to your sales invoice for any specifications regarding this warranty.
- 5 years:** Pulleys, bearings, bronze bushings and guide rods
- 1 year:** Plastic bushings, rubber handgrips, belts, cables, weight stack pins, seat hydraulics and any other parts not specified within the itemized parts
-
- 1 year:** Atlantis accessory bars and handles
- 180 days:** Upholstery
- 90 days:** Other accessory bars and handles

OLYMPIC PLATFORMS

1 year: Manufacturing defects on metal frame, wood and rubber components

180 days: Logo

If at any time a component part is defective, Atlantis shall repair or replace it within a reasonable period of time (at the discretion of Atlantis).

This warranty does not cover costs of removal, transportation or reinstallation. This warranty shall not apply if the defect was caused by misuse, neglect or normal wear and tear.

Atlantis' sole responsibility shall be to repair or replace the component within the terms stated above. Atlantis shall not be liable for any loss or damage of any kind including any incidental or consequential damages resulting directly or indirectly from any warranty expressed or implied or any other failure of this product.

This warranty neither assumes nor authorizes any person to assume obligations other than expressly covered by this warranty.

Atlantis is not responsible for the repair or replacement of any parts that Atlantis determines have been subjected after the date of manufacture to alteration, neglect, abuse, misuse, normal wear and tear, accident, damage during transit or installation, fire, flood or an act of God.

| DAMAGE IN SHIPPING

All Atlantis equipment is carefully inspected and warranted against defects in manufacturing. Responsibility for the safe and timely delivery of equipment rests solely with the transport carrier. It is the responsibility of the consignee to note any damaged or missing goods on the bill of lading prior to signing off, and all claims must be submitted to Atlantis within 48 hours of arrival at delivery site. Failure to comply will invalidate your right to any claim. Damage that is not apparent and discovered after delivery of the equipment must be brought to the attention of Atlantis both verbally and written within 14 days of delivery. Any delays in making such a claim will invalidate your right to any future claim. Please note that pictures and equipment serial numbers as well as invoicing information are required for claim purposes.

| WARRANTY CLAIMS

A claim should include model number, serial number, proof of purchase, date of installation and all pertinent information supporting the existence of the alleged defect. All claims should be submitted via your point of purchase representative or with customer service, both verbally and written. Please refer to Warranty Policy above before submitting a claim.

| CONTACT INFORMATION

Atlantis Inc.

4745 avenue des Industries, Laval, Québec, Canada, H7C 1A1

Tel.: 450-664-2285

Fax: 450-664-4900

Toll free: 1-877-454-2285

Website: www.atlantisstrength.com

Email: service@atlantisstrength.com